

Operating Instructions

1. Manufacturer recommends that two people open and close the Super Simplex.
2. To open, use the “key” end of the operating pole to unlock (if required) the lock cylinder on the latch. Then remove pole from lock cylinder and rotate the operating pole so that the “hook” end is pointing towards the ceiling. Secure the operating pole’s hook into the hole found at the center of the paddle handle latch and carefully pull the door towards you.
3. Now that the door is open, use the pole to engage the eyebolt on the stairway door (see drawing 8 for location) and pull the door until it stops.
4. Remove pole from tee fitting. Reverse procedure to close the unit.

ROUTINE MAINTENANCE

- Inspect springs and cables for wear. Locations are shown on parts list.
- Inspect units for loose bolts, nuts fasteners, etc. Tighten if necessary.
- Lubricate stringer hinges periodically using a lubricant such as WR-40.
- Keep stairway climbing and gripping surfaces as well as footwear free of oil and grease or other slippery substances.
- Inspect treads for any deformation.
- Report any defects or deterioration to your supervisor immediately.

Parts List

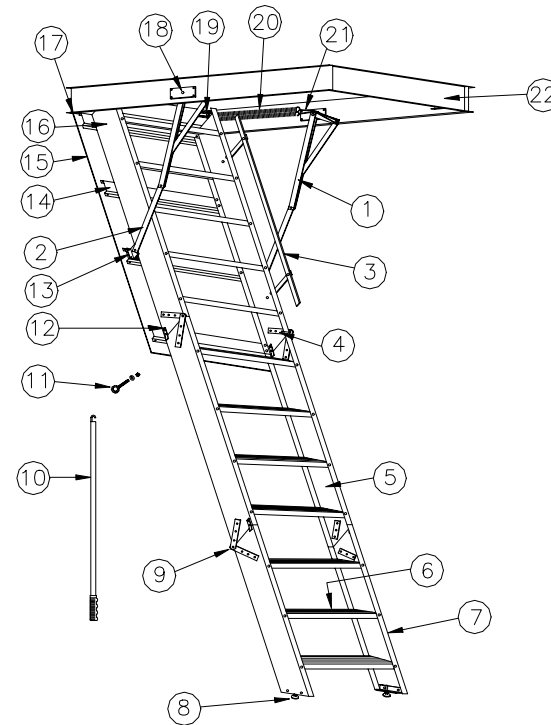

1. Arm assembly (right)
2. Arm Assembly (left)
3. Handrail (steel)
4. Stringer hinge reinforcing plate
5. Middle stringer (specify length or serial number)
6. Serrated aluminum tread
7. Bottom stringer (specify length or serial number)
8. Adjustable foot
9. Stringer hinge
10. Operating pole specify (A) 40” or (B) 60”
11. Eyebolt (washer & nut)
12. Stringer guide (1 set)
13. Pivot bracket
14. Aluminum Batten (A) Top piece only (B) All others
15. Door Panel:
 - (A) 50 1/2” Steel (fire-rated)
 - (B) 60 1/2” Steel (fire-rated)
 - (C) Others: specify serial number or l x w
16. Top Stringer (specify length or serial number)
17. Door hinge
18. Arm mounting plate
19. Spring Brackets
20. Springs (specify length & quantity) 11” or 6.5”
21. Cables
22. Frame unit:
 - (A) 53 1/4” x 29 1/2” x 6”
 - (B) 63 1/4” x 29 1/2” x 6”
 - (C) Others (specify length, width, height)

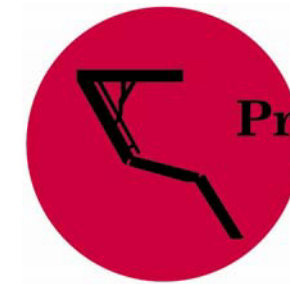

Precision Ladders, LLC

INSTALLATION INSTRUCTIONS and OPERATIONS & MAINTENANCE MANUAL for PRECISION FOLDING STAIRWAYS

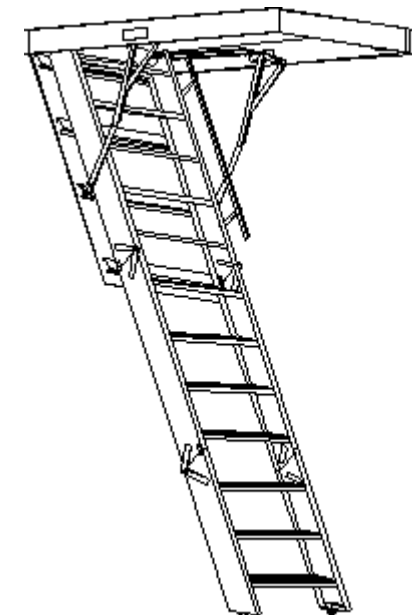

Precision Ladders, LLC
P. O. Box 2279
Morristown, TN 37816-2279
Phone: (423) 586-2265
Fax: (423) 586-2091

Installation Instructions

➤ **Step 1.**

A. Create rough opening to size specified on submittal drawings. If this is a fire-rated model, continue with B and C below, otherwise proceed to Step 2.

B. Identify the following fire-stop materials included within this product's packaging; 4 pcs. of pre-cut .75" thick mineral wool insulation, strapping (to secure insulation). In order to maintain the proper fire-seal between ceiling and frame, you must first prep the frame materials provided. (**Note:** Installation requires fire-stop tape and mineral wool insulation to create a proper fire-seal.) Precision's fire-rated doors can be installed in a variety of combustible and non-combustible ceiling assemblies. The assemblies depicted in drawing 10 are two popular examples. Left Side – shows **combustible** wood and gypsum board ceiling assembly / Right Side – shows **non-combustible** concrete masonry ceiling assembly. Note: All fire-rated doors are self-closing.

C. All Frame Types Place the pieces of pre-cut mineral wool on all four sides of the frame's channel. (see drawing 9) **Notice that the insulation must be secured against the upper angle of the channel in order to allow for 2- layers of gypsum board.** Use strapping to keep insulation in place. The mineral wool insulation should be put in place before the frame is installed in the ceiling's rough opening.

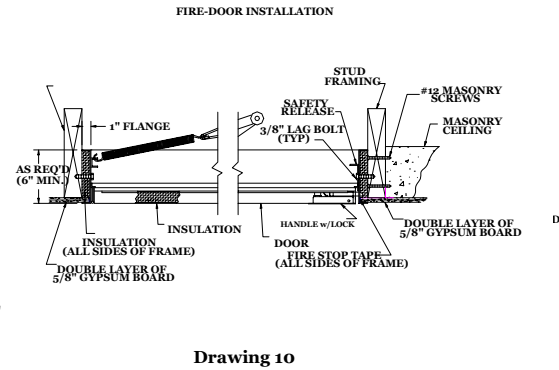
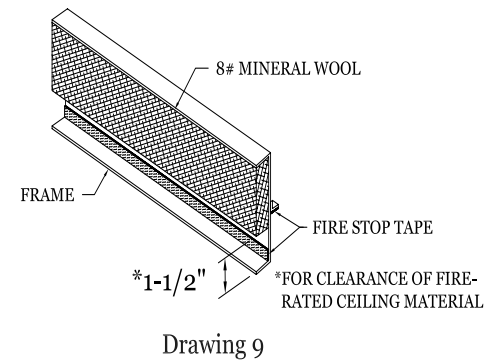

➤ **Step 2.** – Identify the type of frame housing your stairway by comparing the drawings below, and hang the unit following the appropriate instructions.
NOTE: Mounting bolts not included. Precision recommends minimum of 3/8" x 2 1/2" lag or anchor bolts!

Standard Box Frame

A stairway using a standard box frame (drawing 1) is identifiable by the fact that the frame depth is not greater than 11". There are also no mounting brackets.

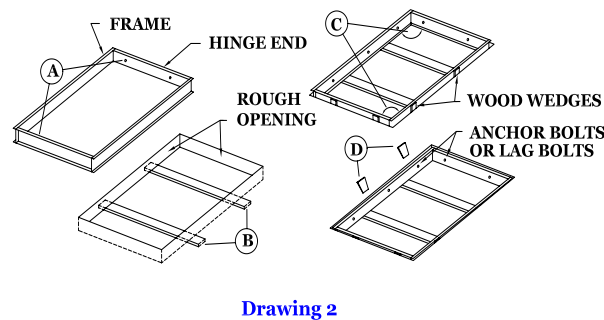
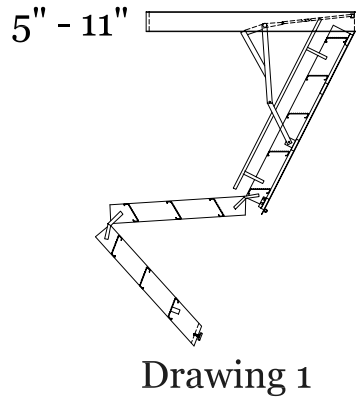

- A. Pre-drill holes in frame (drawing 2), 2 in the hinge end and 2 in the sides on the opposite end.
- B. Attach 2 supporting boards across the rough opening to support the unit while squaring and securing it to the headers of the rough opening.
- C. Place the stairway into the rough opening, check for square, place wedges between frame and rough opening at bolt locations.
- D. Place recommended bolts in pre-drill holes and tighten. Now place additional wedges around the frame as shown, (when finished, unit should have 3 holes per side, 2 per end).
- E. When mounting gypsum board to ceiling, make sure to slide two (2) layers of 5/8" gypsum against frame. The overlap that occurs between the frame's 1" angle and the layered gypsum board is critical when maintaining a fire-rated ceiling assembly. (see drawing A)
- F. Open Stairway. Using a stepladder, drill additional holes at wedge locations, insert bolts and tighten.

IMPORTANT: DO NOT STAND ON STAIR UNTIL ALL BOLTS ARE TIGHTENED!!

G. Proceed to Step 3.

Deep Box Frame or Deep Angle Frame

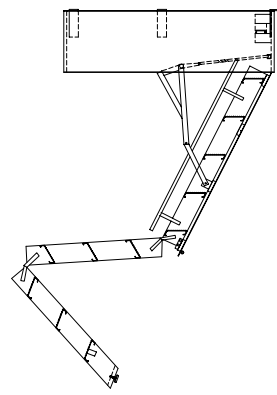

Drawing 3 - Deep Box Frame

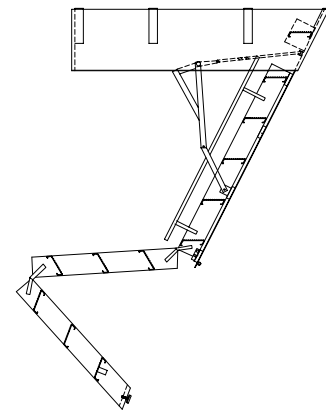

Drawing 4 - Deep Angle Frame

A **deep box frame** (Drawing 3) is just like a standard box frame except that the depth of the frame is greater than 11". The deep box frame also has a series of 1/4" thick mounting brackets along the top of the frame.
A **deep angle frame** (Drawing 4) is identified by the fact that one end is angled at 63 degrees, it too has mounting brackets along the top of the frame.

- A. Make sure frame is square at top & bottom before proceeding.
- B. If possible, lower the entire unit into the rough opening letting it rest on the mounting brackets. If it is not possible to lower the unit into place, remove the mounting brackets, lift the unit through the opening with fork-lift or other type of lift, reattach mounting brackets and lower the unit until it rests on the brackets. Check unit again for square, shim as necessary and bolt into place using recommended bolts.
- C. Proceed to step 3.

DEEP FRAME (BOX OR ANGLE) FOR ROOF ACCESS

A stairway designed for roof access (drawing 5) is identified by a 5" wide flange at the top of the frame. If PRECISION is supplying the hatch will be bolted to the stairway frame through this 5" flange for shipment to the job. The frame can be a 63 degree angle frame as shown in drawing 5, or it can be a box frame (both ends 90 degrees) This entire unit must be lowered into the opening so that the 5" flange rests on the roof deck

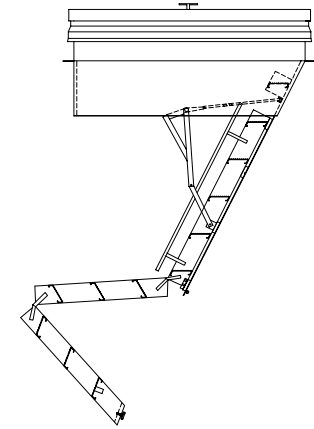

Drawing 5 - Deep Frame w/Hatch

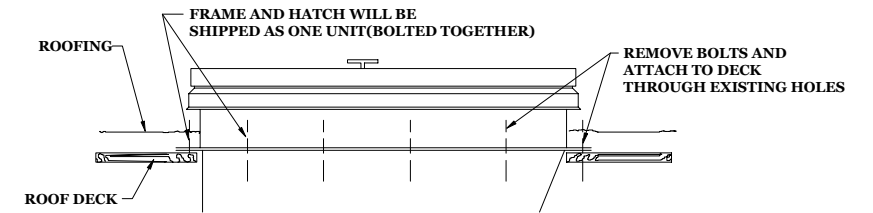

Drawing 6

- A. Make sure frame is square at top and bottom before proceeding.
- B. Lower unit into opening, resting the 5" mounting flange on the roof deck (see drawing 6).
- C. Remove bolts that secure hatch to frame (if hatch is included). Secure the entire unit to the roof deck through these holes using recommended fasteners.
- D. Proceed with Step 3.

➤ **Step 3.** - When the stairway is open and unfolded, it should **JUST** touch the floor. If it is a little too long or short, make the adjustment with the leveling leg at the bottom of the unit. The hinged sections should close when the stairway meets the floor.