

# ROOF HATCH GUARD-RAIL SYSTEM

OSHA GUIDELINE:  
THIS HANDRAIL SYSTEM HAS  
BEEN TESTED TO WITHSTAND  
200# LOADING IN ANY  
DIRECTION.

NOTE:  
SOME SIDE LENGTHS MAY  
REQUIRE A MIDDLE POST  
(NOT SHOWN)

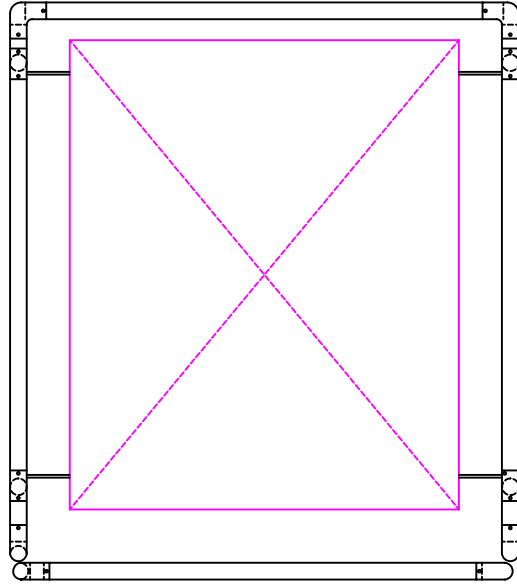

1.25" sch 40 ALUMINUM PIPE  
(1.5" OD NOM)

SELF-CLOSING  
ALUMINUM GATE

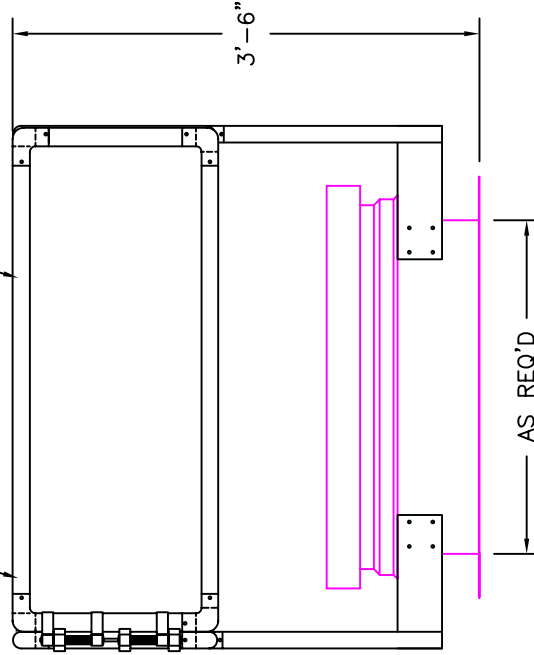

1 5/8"

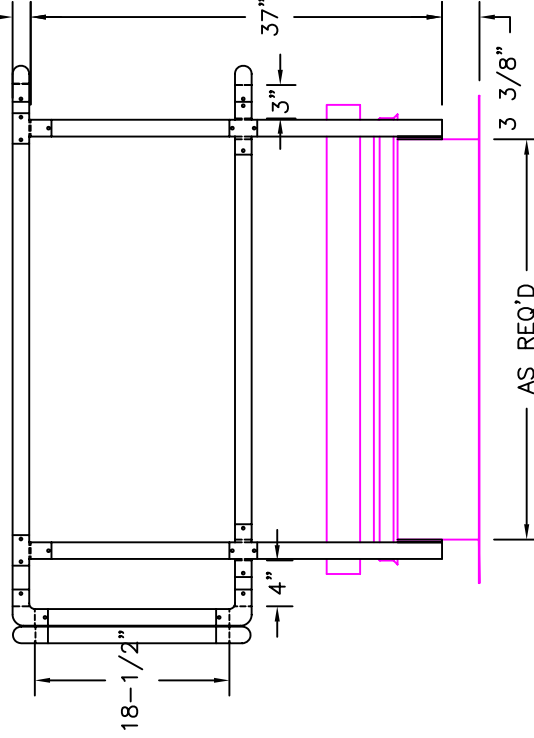

FACTORY FINISH  
ALUMINUM-MILL FINISH

AGRS-H

<b>Precision Ladders, LLC</b> P.O. Box 2279 Morristown, TN 37816-2279 Ph: (423) 586-2265 Fax: (423) 586-2091 www.PrecisionLadders.com	DWG. CHECK	ARCHT OR ENGR.	PROJECT	PRECISION REP
	BUILT BY:	PURCHASE ORDER	WORK ORDER	PURCHASER
CHECKED BY:	DRAWN BY: JBR	DATE: 11/12/08	MODEL#	AGRS-
			QTY.	