

PRECISION AUTOMATIC ELECTRIC DISAPPEARING STAIRWAY

USE THIS DRAWING WHERE FLOOR TO FLOOR DIMENSION IS 14'-0"
OR GREATER AND CEILING TO FLOOR ABOVE IS MORE THAN 13-1/2".

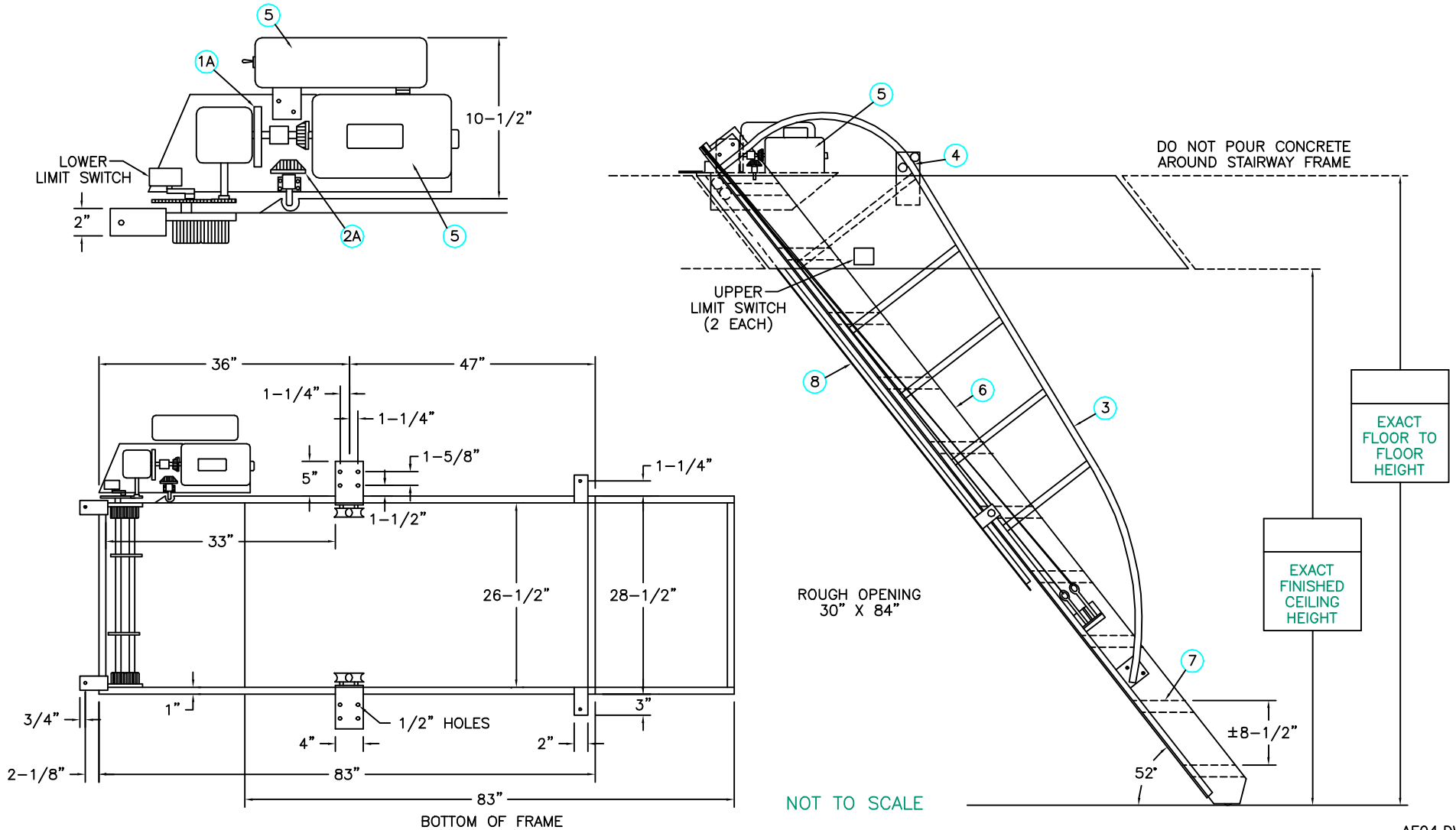

PRECISION Ladders, LLC
 P. O. Box 2279
 MORRISTOWN, TN 37816
 PHONE: (423) 586-2265
 FAX: (423) 586-2091

WORK ORDER ()	DWG. CHECK	ARCH'T OR ENG'R.	PROJECT		GEN'L CONTRACTOR	
	BUILT BY:	PURCHASE ORDER	DATE	PURCHASER	PRECISION REP	
	CHECKED BY:	DRAWN BY:	DATE	MODEL#	QTY.	SERIAL#
		RLW	4/7/98			

AE04.DWG

PART 1: GENERAL

1.01 SUMMARY

- A. Automatic Electric Disappearing Stairway including Stairway, rail, frame, door, drive unit, motor, and controls/junction box.
- B. Products Required, But Not Supplied Under This Section.
 - 1. Required fasteners.
 - 2. Three (3) wire cable and box(es) as required by local codes between stairway control/junction box and power supply source and lower level switch.

1.02 SYSTEM DESCRIPTION

- A. The system requires a ceiling opening of 2'-6" X 6'-0" for floor to floor dimensions up to 14'-0"; and, 2'-6" X 7'-0" for floor to floor dimensions over 14'-0".
- B. Headroom above the second level and behind the at-rest stairway is required. (Consult manufacturer for dimensions)
- C. Unit shall be able to withstand a 2000 lb loading without failure.

1.03 DELIVERY, STORAGE, AND HANDLING.

- A. Examine stairway when it arrives on site. Notify the carrier and manufacturer of any damage.
- B. Store stairway until installation under roof, if possible; or, if stored outside, under a tarp or suitable cover.

1.04 WARRANTY

The unit carries a limited warranty of one (1) year against defective material and workmanship, covering parts only, no labor or freight. Defective parts, if deemed so by the manufacturer, will be replaced no charge, freight excluded, upon inspection at manufacturer's plant which warrants same.

1.05 MAINTENANCE

- A. Under normal usage, the stairway shall require preventive maintenance as specified in the installation instructions supplied with the unit.
- B. No "spare parts" shall be required.

PART 2: PRODUCTS

2.01 MANUFACTURER

Precision Ladders, LLC P. O. Box 2279, Morristown, Tennessee 37816.
Phone: (800)225-7814. FAX: (423)586-2091.

2.02 MATERIALS

A. STAIRWAY

- 1. Stringers
 - 1.1 7" X 0.230" extruded aluminum channel.
 - 1.2 Steel rollers at base of each stringer.
 - 1.3 Pitch 52° (standard). Other pitches optional.
- 2. Treads
 - 2.1 Aluminum channel 6" X 20 3/16" X 0.225".
 - 2.2 Treads covered with nonskid safety material
 - 2.3 9 1/2" riser height (std). Other heights available.

B. RAIL

Hand/guide rail 1 1/16" O.D. galvanized, both sides.

C. FRAME

1. 1/8" steel formed channel.
2. Height to suit total ceiling thickness.

D. DOOR

1. 1/8" aluminum panel (std) or 1 3/4" wood with mineral core (optional)
2. Steel piano hinge.

E. DRIVE UNIT

1. 1/3 horsepower, 115 volt instantly reversible motor direct-connected to a reduction gear drive, complete with contactors.
2. Pre-wired control switches.

F. HARDWARE

1. Sealed ball bearing guides.
3. Double 1/8" aircraft cable drive.

G. MANUFACTURED UNITS

The Automatic Electric disappearing stairway is a Model AE**. (** floor to floor height in inches)

H. ACCESSORIES

1. Optional emergency manual operation to lower (only) if power fails from above.
2. Same as 1, but from below.
3. Key operated dead-man type wall switch, in place of standard toggle switch.
4. Warning buzzer

I. FABRICATION

The stairway is completely fabricated in an ISO 9002 Certified facility, ready for installation before shipment to the site.

J. FINISHES

1. Mill finish on aluminum stairway components.
2. Prime coat on frame.
3. Galvanized hand rails.

K. SOURCE QUALITY CONTROL

1. All products inspected at factory.
2. All products tested in factory test jig for proper operation before shipment.

PART 3: EXECUTION

3.01 EXAMINATION

Examine rough opening in ceiling for opening size and squareness.

3.02 INSTALLATION

Install per the manufacturer's installation instructions.

3.03 FIELD QUALITY CONTROL

The manufacturer has representatives in all areas of the United States and Canada. For the name of the closest representative, telephone (800)225-7814.